



FLOW CONTROL (AND CHECK) VALVES

FG -01/02/03/06/10 (1/8,1/4,3/8,3/4,1-1/4)
FCG

PILOT OPERATED FLOW CONTROL (AND CHECK) VALVES

FHG -02/03/06/10 (1/4,3/8,3/4,1-1/4)
FHCG

Sub-plate Mounting

FLOW CONTROLS

Up to 21 MPa (3050 PSI), 500 L/min (132 U.S.GPM)

■ **Flow Control and Check Valves** Page 2

These valves are pressure and temperature compensating type valves and maintain a constant flow rate independent of change in system pressure (load) and temperature (viscosity of the fluid). They control flow rate of the hydraulic circuit and eventually control speed of the actuator precisely.

Valves with an integral check valve allow a controlled flow and reverse free flow. Repeated resetting can be made easily with a digital readout.

■ **Pilot Operated Flow Control and Check Valves** Page 14

Flow control of these valves is continuously made by a hydraulically operated pilot piston mechanism which controls opening area of the orifice of the valve. With the use of these valves, shockless operation either in acceleration or deceleration can be obtained. With the compensator for the pressure and temperature, stable flow control can be obtained regardless of the changes in the pressure (load) and temperature (oil viscosity).

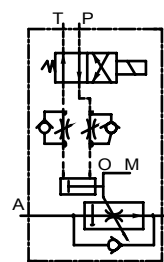
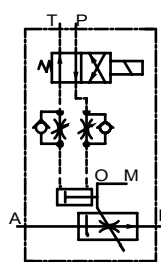
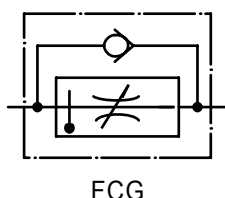
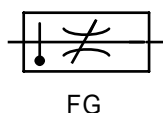
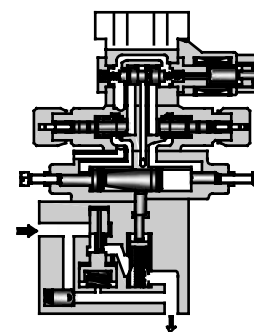
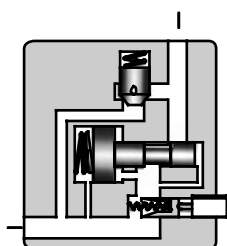

■ **Hydraulic Fluids**

● **Fluid Types**

Any type of hydraulic fluids listed in the table below can be used.

Petroleum base oils	Use fluids equivalent to ISO VG 32 or VG 46.
Synthetic fluids	Use phosphate ester or polyol ester fluid. When phosphate ester fluid is used, prefix "F-" to the model number because the special seals (fluororubber) are required to be used.
Water containing fluids	Use water-glycol fluid.

Note: For use with hydraulic fluids other than those listed above, please consult your Yuken representatives in advance.

● **Recommended Viscosity and Oil Temperatures**

Viscosity ranging between 15 - 400 mm²/s (77 - 1800 SSU).

Oil temperatures between -15/+70°C (5 - 158°F).

Use hydraulic fluids which satisfy the recommended viscosity and oil temperatures given above.

● **Control of Contamination**

Due caution must be paid to maintaining control over contamination of the hydraulic fluids which may otherwise lead to breakdowns and shorten the life of the valves. Please maintain the degree of contamination within NAS 1638-Grade 12. Use 25 μm or finer line filter.

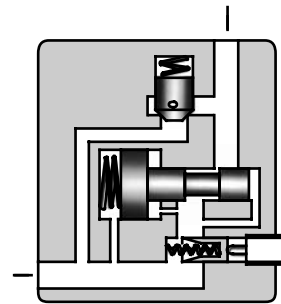

Specifications

Model Numbers	Max. Metred Flow Capacity L/m in (U.S.GPM)	Min. Metred Flow Capacity L/m in (U.S.GPM)	Max. Operating Pressure MPa (PSI)	Approx. Mass kg (lbs.)
FG -01-4 FCG -01-8*-11*	8 (2.1)	0.02 (.005) {0.04 (.011)} *	14 (2030)	1.3 (2.9)
FG -02-30*-30*	30 (7.9)	0.05 (.013)	21 (3050)	3.8 (8.4)
FG -03-125*-30*	125 (33)	0.2 (.053)		7.9 (17.4)
FG -06-250*-30*	250 (66)	2 (.53)		23 (50.7)
FG -10-500*-30*	500 (132)	4 (1.06)		52 (115)

* The figures in the brace are for pressures above 7 MPa (1020 PSI).

Model Number Designation

F-	FC	G	-01	-8	-N	-11	*
Special Seals	Series Number	Type of Mounting	Valve Size	Max. Metred Flow Capacity L/m in (U.S.GPM)	Pres. Compensator Stroke Adjustment	Design Number	Design Standards
F: Special Seals for Phosphate Ester Type Fluids (Omit if not required)	F: Flow Control Valves FC: Flow Control and Check Valves	G: Sub-plate Mounting	01 02 03 06 10	4 : 4 (1.06) 8 : 8 (2.1) 30 : 30 (7.9) 125 : 125 (33) 250 : 250 (66) 500 : 500 (132)	N: Applicable only for Pres. Compensator Stroke Adjustment (Option - Om it if not required)	11 30 30 30 30	Refer to ★

★ Design Standards: None Japanese Standard "JIS" and European Design Standard
90 N. American Design Standard

Attachment

Mounting Bolts

Valve Model Numbers	Socket Head Cap Screw		Qty.
	Japanese Std. "JIS" & European Design Std.	N. American Design Std.	
FG/FCG-01	M5 ×55 Lg.	No.10-24 UNC × 2-1/4 Lg.	4
FG/FCG-02	M8 ×50 Lg.	5/16-18 UNC × 2 Lg.	4
FG/FCG-03	M10 ×75 Lg.	3/8-16 UNC × 3 Lg.	4
FG/FCG-06	M16 ×130 Lg.	5/8-11 UNC × 5 Lg.	4
FG/FCG-10	M20 ×160 Lg.	3/4-10 UNC × 6-1/2 Lg.	4

Option

Pres. compensator stroke adjustment

Can reduce jumping at the start of the actuator.

Graphic Symbols

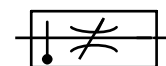

FG

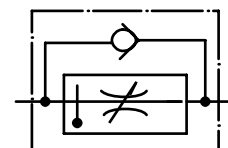

FCG

■ Sub-plate

Valve Model Numbers	Japanese Standard "JIS"		European Design Std.		N. American Design Std.		Approx. Mass kg (lbs.)
	Sub-plate Model No.	Thread Size	Sub-plate Model No.	Thread Size	Sub-plate Model No.	Thread Size	
FG FCG-01	FGM-01X-10	Rc 1/4	FGM-01X-1080	1/4 BSP.F	FGM-01X-1090	1/4 NPT	0.8 (1.8)
FG FCG-02	FGM-02-20	Rc 1/4	FGM-02-2080	1/4 BSP.F	FGM-02-2090	1/4 NPT	2.3 (5.1)
	FGM-02X-20	Rc 3/8	FGM-02X-2080	3/8 BSP.F	FGM-02X-2090	3/8 NPT	2.3 (5.1)
	FGM-02Y-20	Rc 1/2	FGM-02Y-2080	1/2 BSP.F	FGM-02Y-2090	1/2 NPT	3.1 (6.8)
FG FCG-03	FGM-03-20	Rc 3/8	FGM-03-2080	3/8 BSP.F	FGM-03-2090	3/8 NPT	3.9 (8.6)
	FGM-03X-20	Rc 1/2	FGM-03X-2080	1/2 BSP.F	FGM-03X-2090	1/2 NPT	3.9 (8.6)
	FGM-03Y-20	Rc 3/4	FGM-03Y-2080	3/4 BSP.F	FGM-03Y-2090	3/4 NPT	5.7 (12.6)
	FGM-03Z-20	Rc 1	FGM-03Z-2080	1 BSP.F	FGM-03Z-2090	1 NPT	5.7 (12.6)
FG FCG-06	FGM-06X-20	Rc 1	FGM-06X-2080	1 BSP.F	FGM-06X-2090	1 NPT	12.5 (27.6)
	FGM-06Y-20	Rc 1-1/4	FGM-06Y-2080	1-1/4 BSP.F	FGM-06Y-2090	1-1/4 NPT	16 (35.3)
	FGM-06Z-20	Rc 1-1/2	FGM-06Z-2080	1-1/2 BSP.F	FGM-06Z-2090	1-1/2 NPT	16 (35.3)
FG FCG-10	FGM-10Y-20*	1-1/2, 2	FGM-10Y-20*	1-1/2, 2	FGM-10Y-2090*	1-1/2, 2	37 (81.6)

● Sub-plates are available. Specify the sub-plate model number from the table above. When sub-plates are not used, the mounting surface should have a good machined finish.

★FGM-10Y is special type sub-plate to be used with pipe flange. When ordering FGM-10Y, specify pipe flange kit in addition to FGM-10Y referring to F3 pipe flange kits Catalogue (No. Pub. EC-3001).

■ Instructions

● Min. required pressure difference

The minimum differential pressure between inlet and outlet port is required to obtain the optimum pressure compensation. It varies according to the flow rate to be set. For details, please refer to the performance curves.

● Free flow

Check valve pressure drops vary with flow rates. If models with check valves are used, see free flow pressure drop characteristics.

● Flow adjustment

[F*G-01]

Loosen the locking screw and turn the flow adjustment dial clockwise for increase, and anti-clockwise for decrease. The dial makes about 4 revolutions from zero to full flow and the valve opening is indicated on the revolution indicator. (Refer to characteristics of "Metred Flow vs. Dial Position").

After flow adjustments, tighten the locking screw.

[F*G-02, 03, 06, 10]

Loosen the locking screw and turn the flow adjustment handle clockwise for increase, and anti-clockwise for decrease. Open condition is indicated in digital-scale in built-in revolution indicator (Refer to the characteristics of "Metred Flow vs. Dial Position").

After flow adjustments, tighten the locking screw.

● Line filter

To carry out flow adjustments by as small degree as 2 L/min (.53 U.S.GPM) or less, be sure to use a line filter of 10 μm or finer and install it near the valve inlet.



FG/FCG-01-*-*-11/1190

DIMENSIONS IN
MILLIMETRES (INCHES)

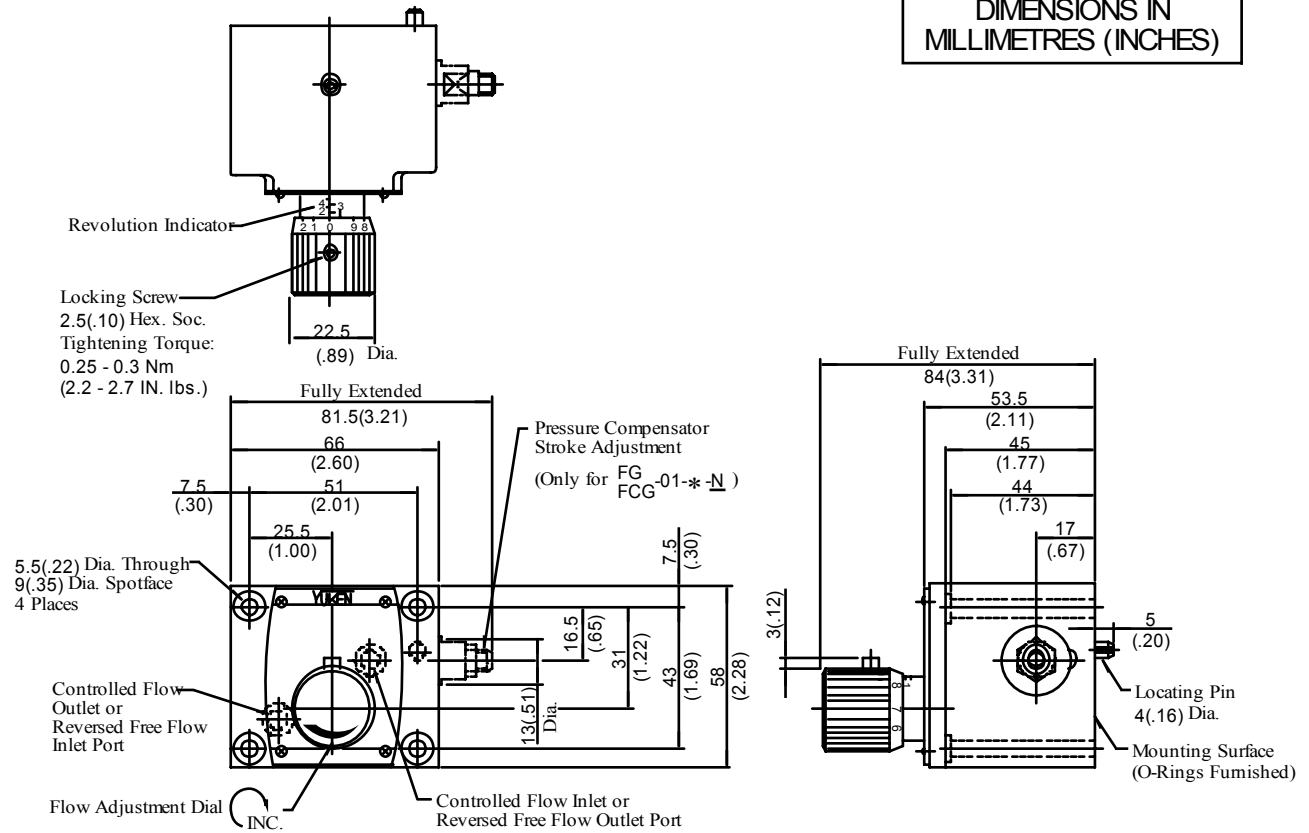

FG/FCG-02-30-*-*30/3090, FG/FCG-03-125-*-*30/3090

Mounting surface:
F* G-02: ISO 6263-AB-06-4-B
F* G-03: ISO 6263-AK-07-2-A

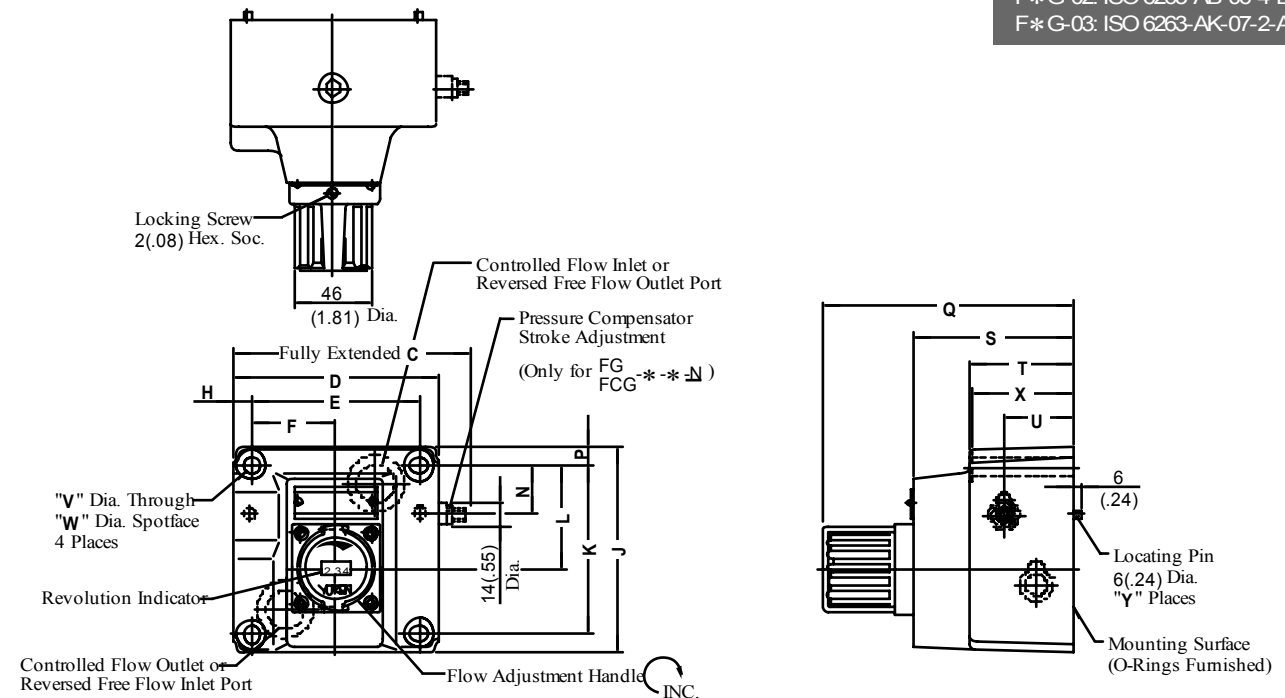

Model No.	Dimensions mm (Inches)																	Y
	C	D	E	F	H	J	K	L	N	P	Q	S	T	U	V	W	X	
FG FCG-02	116 (4.57)	96 (3.78)	76.2 (3.00)	38.1 (1.50)	9.9 (.39)	104.5 (4.11)	82.6 (3.25)	44.3 (1.74)	24 (.94)	9.9 (.39)	123 (4.84)	69 (2.72)	40 (1.57)	23 (.91)	8.8 (.35)	14 (.55)	39 (1.54)	1
FG FCG-03	145 (5.71)	125 (4.92)	101.6 (4.00)	50.8 (2.00)	11.7 (.46)	125 (4.92)	101.6 (4.00)	61.8 (2.43)	29.8 (1.17)	11.7 (.46)	152 (5.98)	98 (3.86)	64 (2.52)	41 (1.61)	11 (.43)	17.5 (.69)	63 (2.48)	2

FG/FCG-06-250-* -30/3090
FG/FCG-10-500-* -30/3090

Mounting surface:
F*G-06: ISO 6263-AP-08-2-A

DIMENSIONS IN
MILLIMETRES (INCHES)

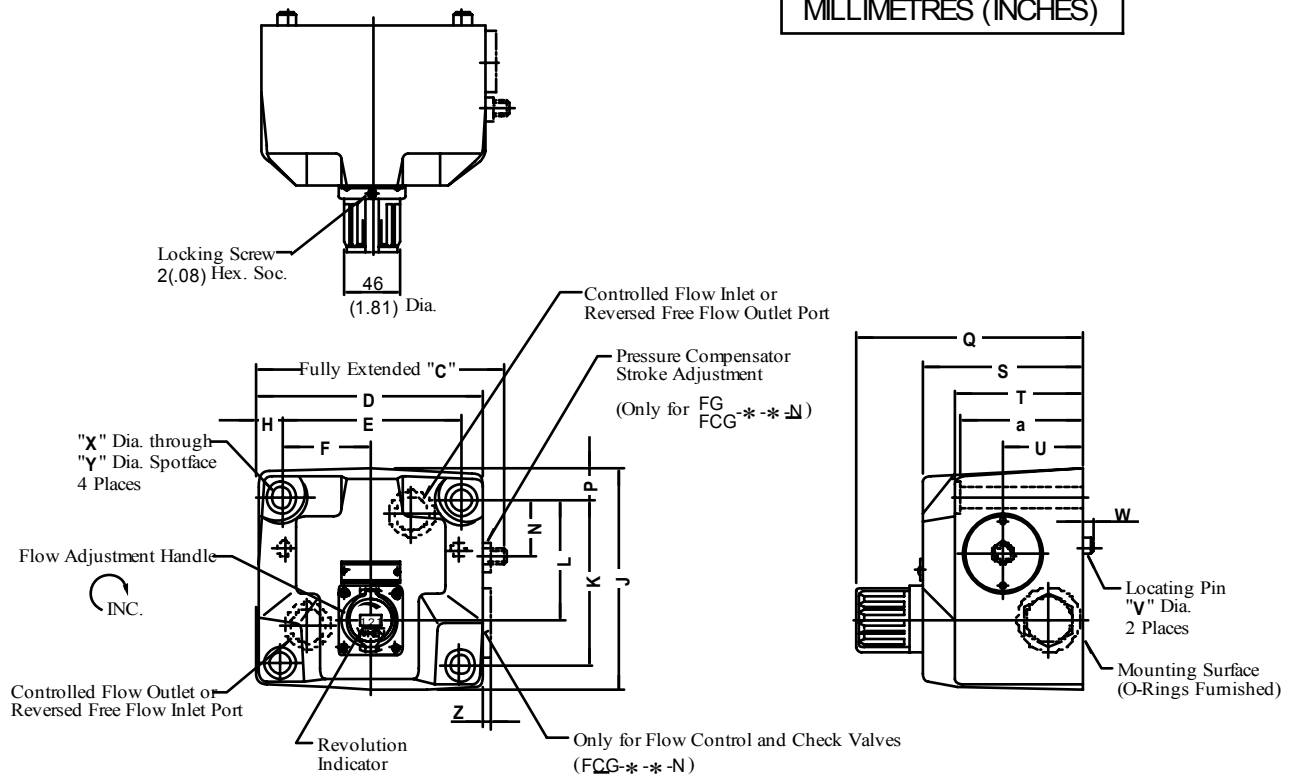

Model No.	Dimensions mm (Inches)																			
	C	D	E	F	H	J	K	L	N	P	Q	S	T	U	V	W	X	Y	Z	a
FG FCG ⁻⁰⁶	198 (7.80)	180 (7.09)	146.1 (5.75)	73 (2.87)	17 (.67)	174 (6.85)	133.4 (5.25)	99 (3.90)	44 (1.73)	20.3 (.80)	184 (7.24)	130 (5.12)	105 (4.13)	65 (2.56)	16 (.63)	7 (.28)	17.5 (.69)	26 (1.02)	9 (.35)	103 (4.06)
FG FCG ⁻¹⁰	267 (10.51)	244 (9.61)	196.9 (7.75)	98.5 (3.88)	23.5 (.93)	228 (8.98)	177.8 (7.00)	144.5 (5.69)	61 (2.40)	25 (.98)	214 (8.43)	160 (6.30)	137 (5.39)	85 (3.35)	18 (.71)	10 (.39)	21.5 (.85)	32 (1.26)	7.5 (.30)	135 (5.31)

FGM-01X-10/1080/1090

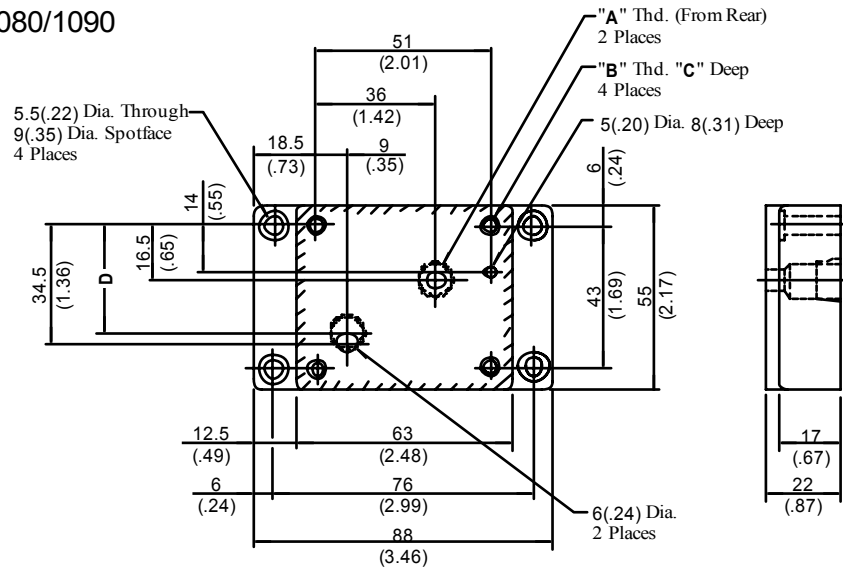

Sub-plate Model Numbers	"A" Thd.	"B" Thd.	C	D
FGM-01X-10	Rc 1/4	M5	14 (.55)	34.5 (1.36)
FGM-01X-1080	1/4 BSP.F	M5	14 (.55)	30.0 (1.18)
FGM-01X-1090	1/4 NPT	No.10-24 UNC	15 (.59)	34.5 (1.36)

**DIMENSIONS IN
MILLIMETRES (INCHES)**

02
FGM-02X-20/2080/2090
02Y

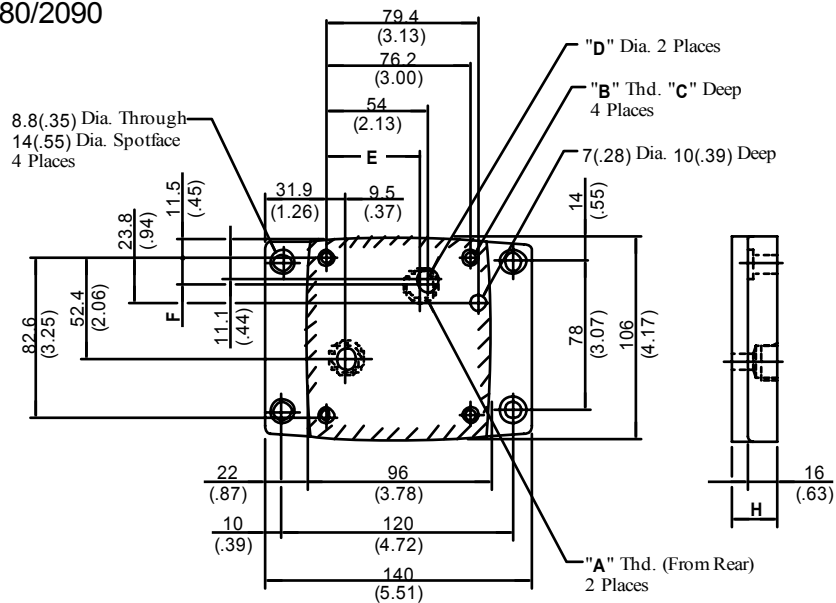

Sub-plate Model Numbers	"A" Thd.	"B" Thd.	C	D	E	F	H			
FGM-02-20	Rc 1/4	M8	14 (.55)	11.0 (.43)	54 (2.13)	11.1 (.44)	25 (.98)			
FGM-02-2080	1/4 BSP.F			11.7 (.46)						
FGM-02-2090	1/4 NPT	5/16-18 UNC	18 (.71)	11.0 (.43)						
FGM-02X-20	Rc 3/8	M8	14 (.55)	14.0 (.55)						
FGM-02X-2080	3/8 BSP.F			15.2 (.60)						
FGM-02X-2090	3/8 NPT			5/16-18 UNC				18 (.71)	14.0 (.55)	
FGM-02Y-20	Rc 1/2	M8	14 (.55)	14.0 (.55)				51 (2.01)	14 (.55)	35 (1.38)
FGM-02Y-2080	1/2 BSP.F			15.0 (.59)						
FGM-02Y-2090	1/2 NPT			5/16-18 UNC	18 (.71)	14.0 (.55)				

03
FGM-03X-20/2080/2090
03Y
03Z

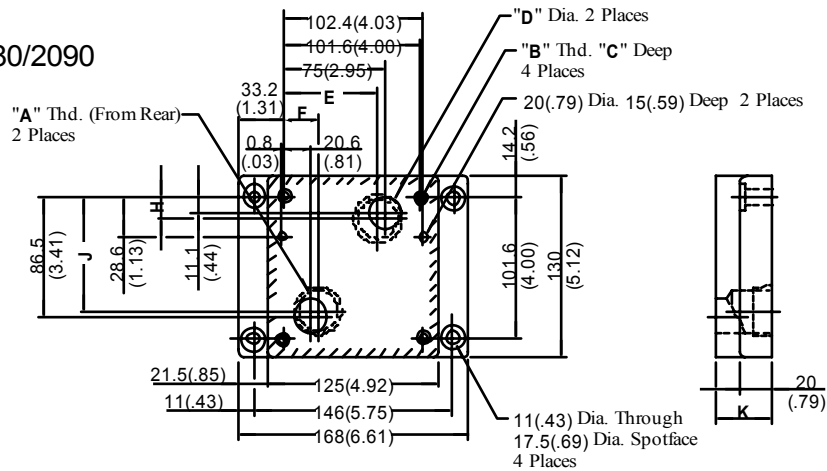

Sub-plate Model Numbers	"A" Thd.	"B" Thd.	C	D	E	F	H	J	K
FGM-03-20	Rc 3/8	M10	18 (.71)	14.0 (.55)	75 (2.95)	20.6 (.81)	11.1 (.44)	86.5 (3.41)	25 (.98)
FGM-03-2080	3/8 BSP.F			15.0 (.59)					
FGM-03-2090	3/8 NPT	3/8-16 UNC	21 (.83)	14.0 (.55)					
FGM-03X-20	Rc 1/2	M10	18 (.71)	17.5 (.69)	70 (2.76)	25.6 (1.01)	16.1 (.63)	81.5 (3.21)	40 (1.57)
FGM-03X-2080	1/2 BSP.F			19.0 (.75)					
FGM-03X-2090	1/2 NPT	3/8-16 UNC	21 (.83)	17.5 (.69)					
FGM-03Y-20	Rc 3/4	M10	18 (.71)	23.0 (.91)	70 (2.76)	25.6 (1.01)	16.1 (.63)	81.5 (3.21)	40 (1.57)
FGM-03Y-2080	3/4 BSP.F								
FGM-03Y-2090	3/4 NPT	3/8-16 UNC	21 (.83)						
FGM-03Z-20	Rc 1	M10	18 (.71)	23.0 (.91)	70 (2.76)	25.6 (1.01)	16.1 (.63)	81.5 (3.21)	40 (1.57)
FGM-03Z-2080	1 BSP.F								
FGM-03Z-2090	1 NPT	3/8-16 UNC	21 (.83)						

DIMENSIONS IN
MILLIMETRES (INCHES)

06X
FGM-06Y-20/2080/2090
06Z

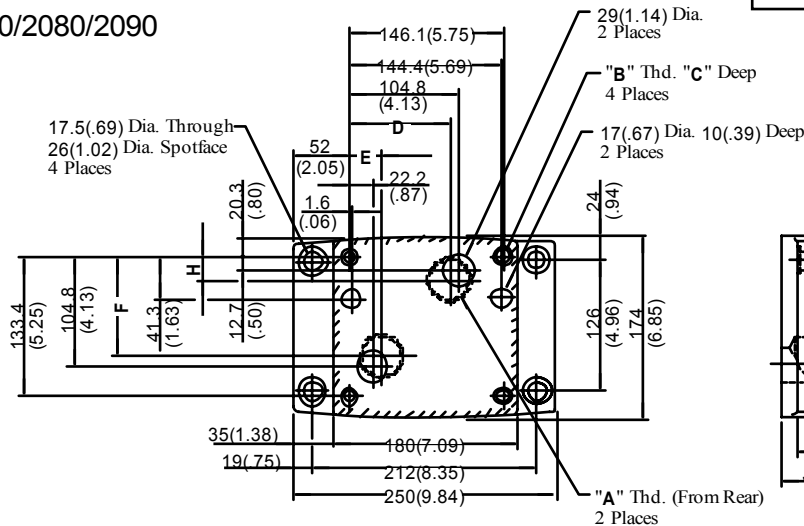

Sub-plate Model Numbers	"A" Thd.	"B" Thd.	C	D	E	F	H	J	K
FGM-06X-20	Rc 1	M16	30 (1.18)	104.8 (4.13)	22.2 (.87)	104.8 (4.13)	18 (.71)	45 (1.77)	35 (1.38)
FGM-06X-2080	1 BSP.F								
FGM-06X-2090	1 NPT	5/8-11 UNC	35 (1.38)						
FGM-06Y-20	Rc 1-1/4	M16	30 (1.18)	99 (3.90)	34 (1.34)	99 (3.90)	23 (.91)	60 (2.36)	40 (1.57)
FGM-06Y-2080	1-1/4 BSP.F								
FGM-06Y-2090	1-1/4 NPT	5/8-11 UNC	35 (1.38)						
FGM-06Z-20	Rc 1-1/2	M16	30 (1.18)	99 (3.90)	34 (1.34)	99 (3.90)	23 (.91)	60 (2.36)	40 (1.57)
FGM-06Z-2080	1-1/2 BSP.F								
FGM-06Z-2090	1-1/2 NPT	5/8-11 UNC	35 (1.38)						

FGM-10Y-20/2090

DIMENSIONS IN
MILLIMETRES (INCHES)

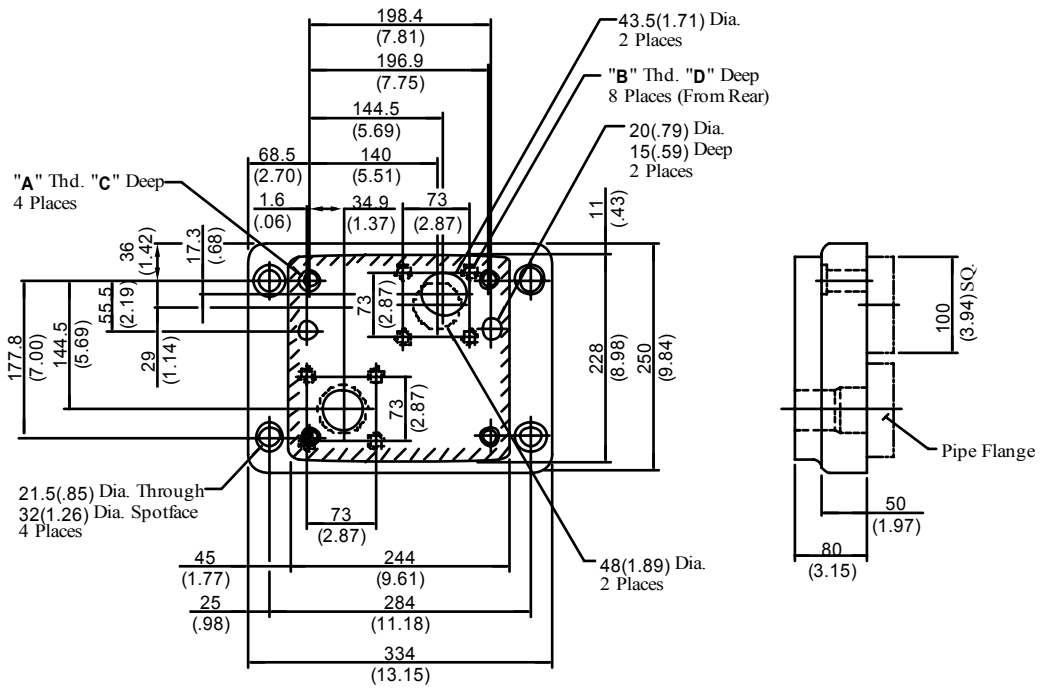

Sub-plate Model Numbers	"A" Thd.	"B" Thd.	C	D
FGM-10Y-20	M20	M16	32 (1.26)	32 (1.26)
FGM-10Y-2090	3/4-10 UNC	5/8-11 UNC	32 (1.26)	34 (1.34)

Metred Flow vs. Differential Pressure

Metred Flow vs. Viscosity

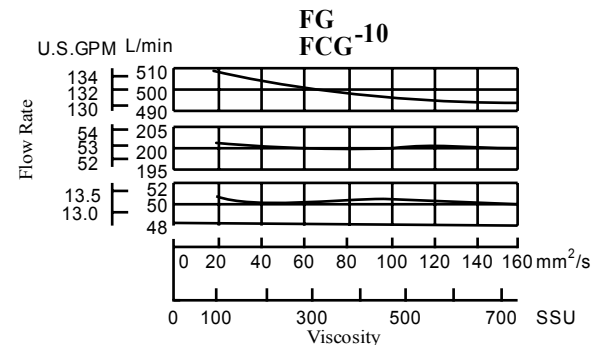
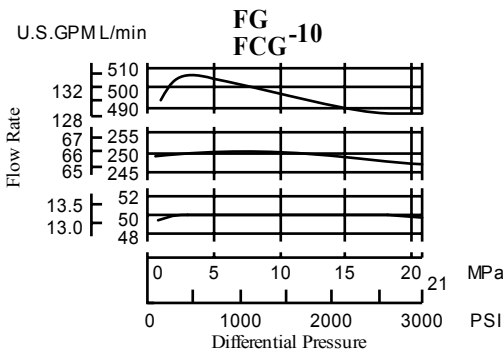
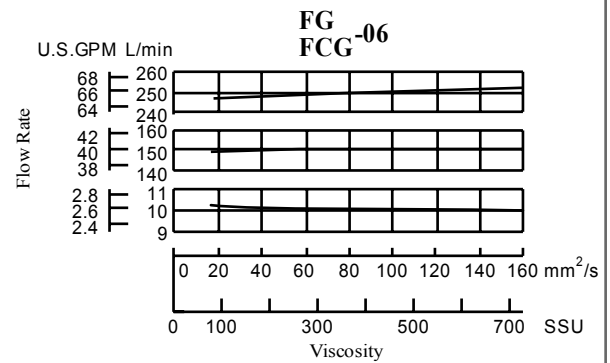
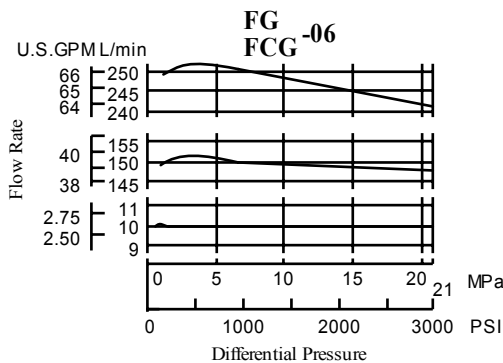
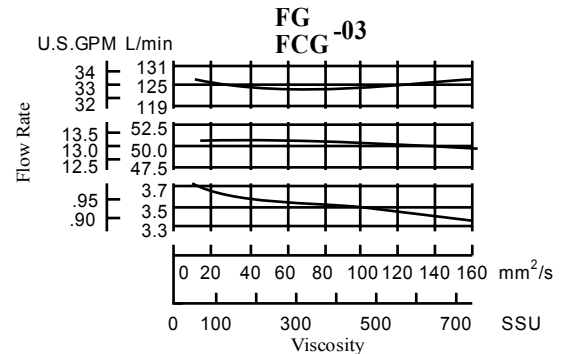
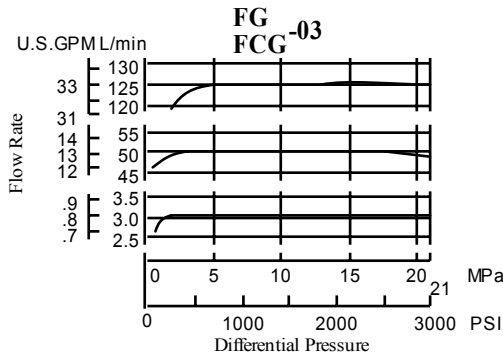
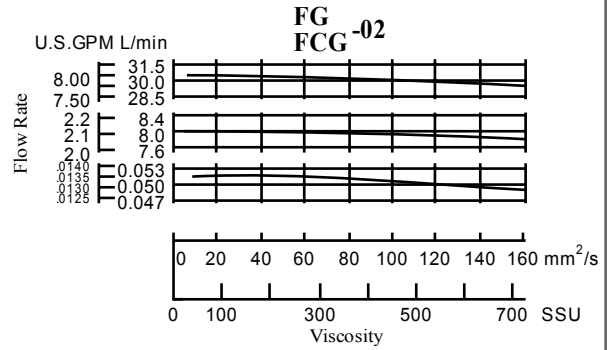
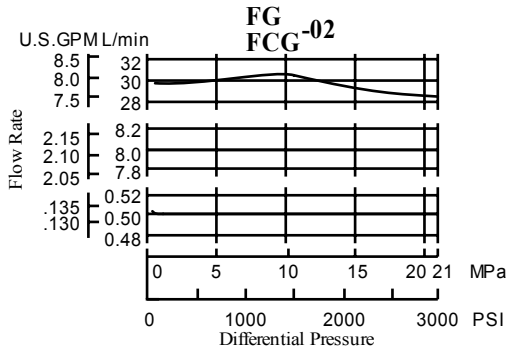
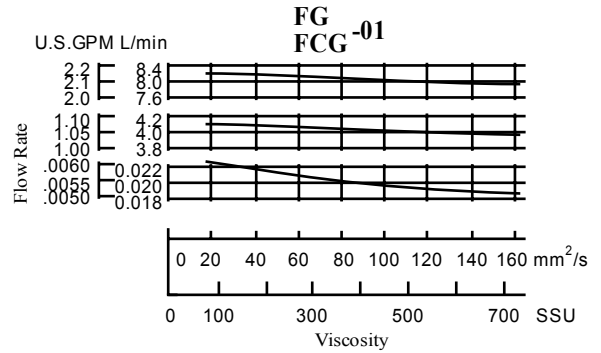
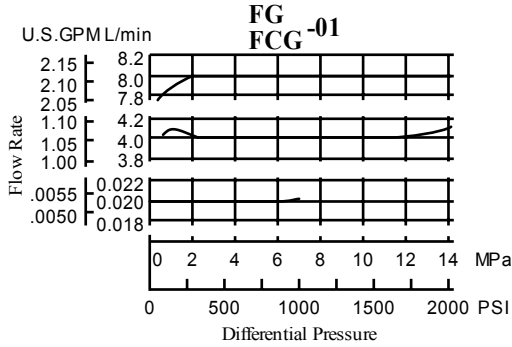

Metred Flow vs. Dial Position

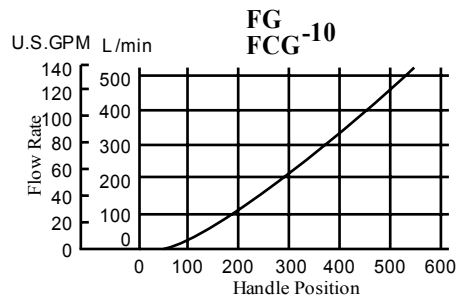
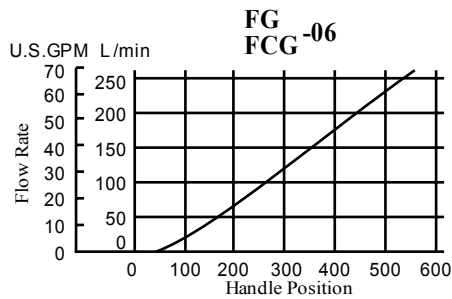
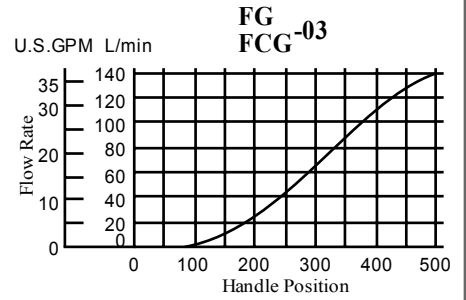
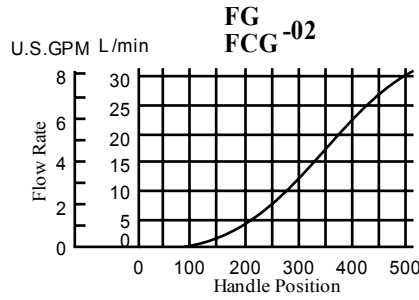
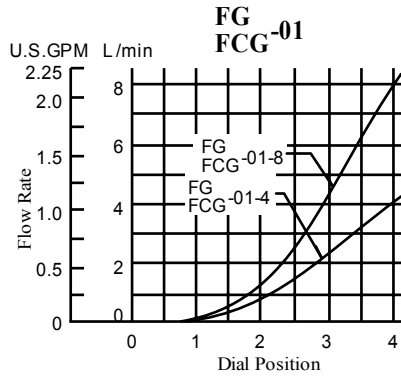

Min. Required Pressure Difference

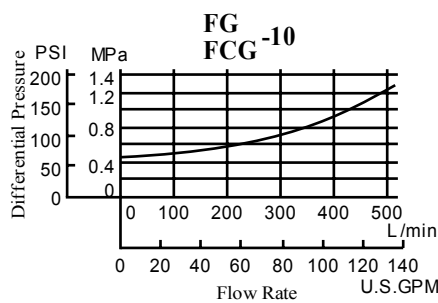
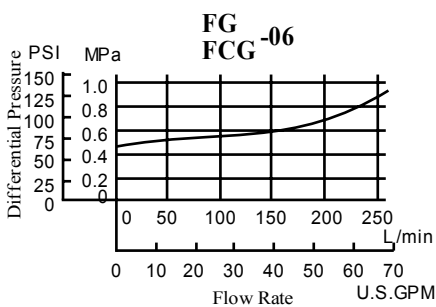
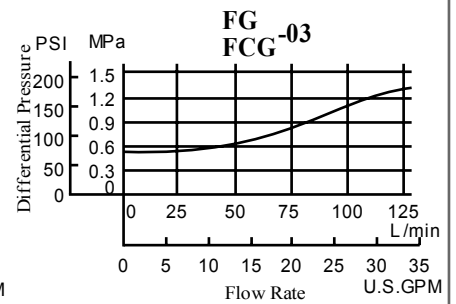
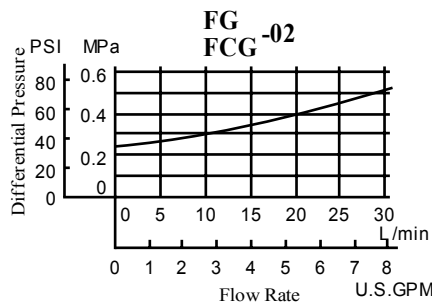
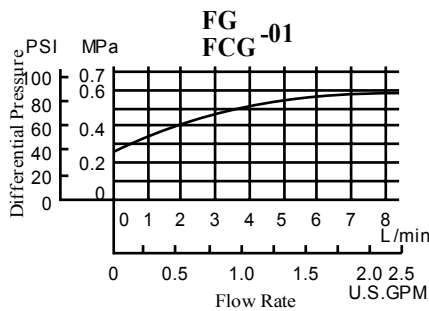

■ Pressure Drop for Reversed Free Flow

Hydraulic Fluid: Viscosity 35 mm²/s (164 SSU), Specific Gravity 0.850

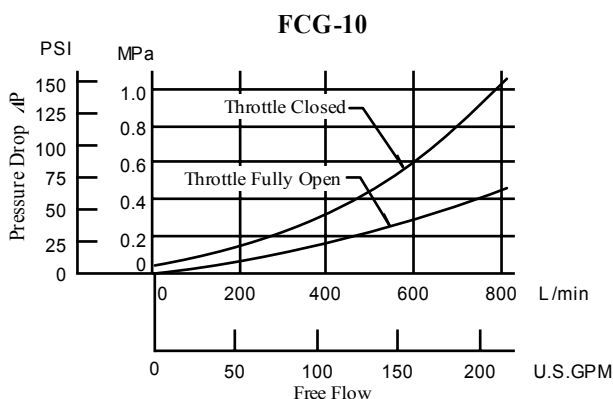
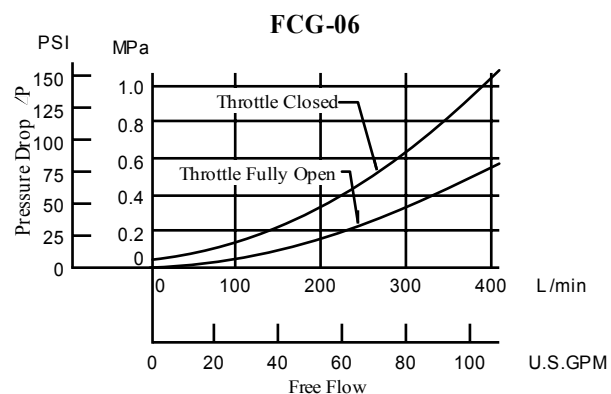
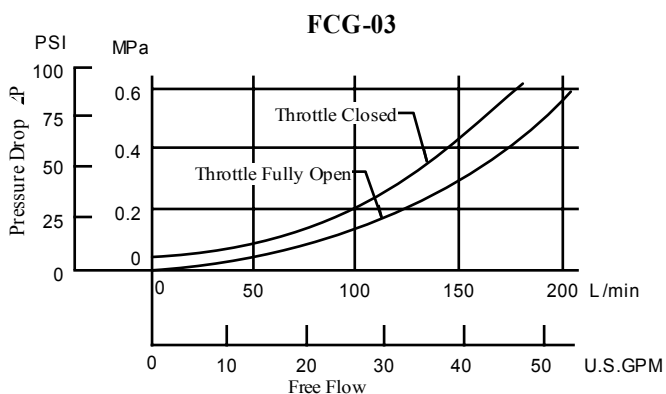
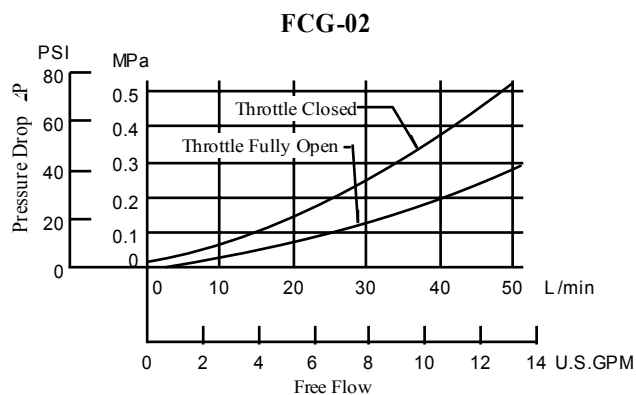
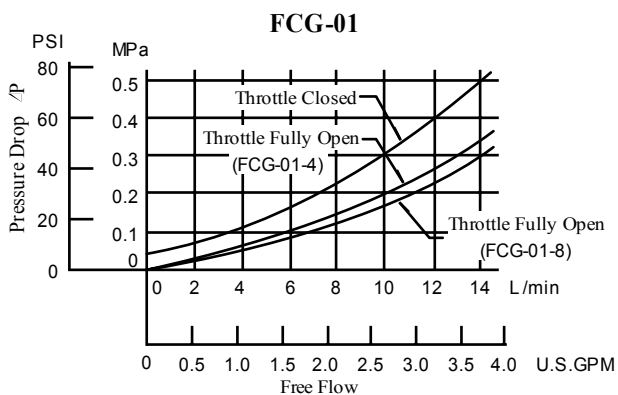

- For any other viscosity, multiply the factors in the table below.

Viscosity	mm ² /s	20	40	60	80	100
	SSU	98	186	278	371	464
Factor		0.87	1.03	1.14	1.23	1.30

- For any other specific gravity (G'), the pressure drop ($\Delta P'$) may be obtained from the formula below.
 $\Delta P' = \Delta P (G'/0.850)$



FG
FCG-01-*-*-11/1190

CAUTION

When making replacement of seals, please do it carefully after reading through the relevant instructions in the Operator's Manual.

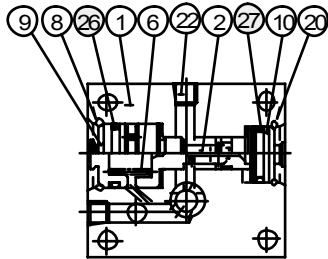

Section X-X
(FG-01 Type)

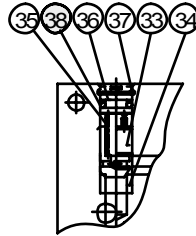

Section Y-Y
(FCG-01 Type)

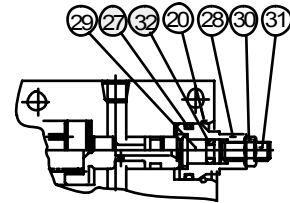

Section X-X
(FG/FCG-01-*-N Type)

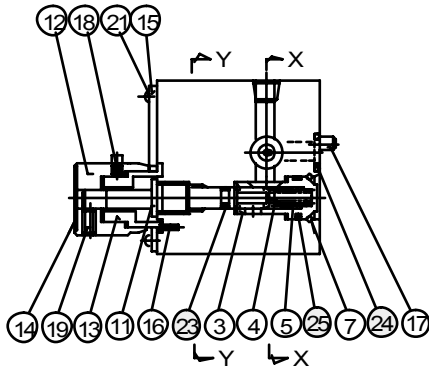

● List of Seals

Item	Name of Parts	Part Numbers	Qty.
23	O-Ring	SO-NA-P4	1
24	O-Ring	SO-NB-P9	2
25	O-Ring	SO-NB-P10	1
26	O-Ring	SO-NB-P16	1
27	O-Ring	SO-NB-P14	1
32	O-Ring	SO-NA-P5	1
38	O-Ring	SO-NB-P7	1

Note: When ordering the seals, please specify the seal kit number from the table below.

● List of Seal Kits

Model Numbers	Seal Kit Numbers
FG-01	KS-FG-01-11
FCG-01	KS-FCG-01-11

FG/FCG-02-30-* -30/3090
FG/FCG-03-125-* -30/3090

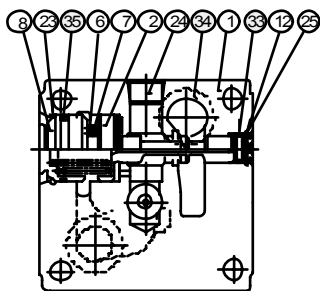

Section X-X
(FG-* Type)

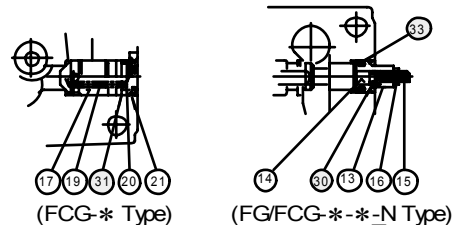
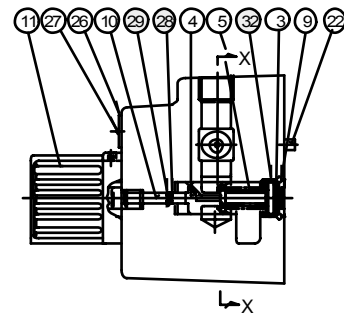

Section X-X

● List of Seals

Item	Name of Parts	Part Numbers		Qty.
		FG FCG -02	FG FCG -03	
28	O-Ring	SO-NA-P4	SO-NA-P4	1
29	Back Up Ring	SO-BB-P4	SO-BB-P4	1
30	O-Ring	SO-NB-P5	SO-NB-P5	1
31	O-Ring	SO-NB-P10A	SO-NB-P16	1
32	O-Ring	SO-NB-P12	SO-NB-P18	1
33	O-Ring	SO-NB-P14	SO-NB-P14	1
34	O-Ring	SO-NB-P18	SO-NB-P28	2
35	O-Ring	SO-NB-G25	SO-NB-G35	1

Note: When ordering the seals, please specify the seal kit number from the table right.

● List of Seal Kits

Model Numbers	Seal Kit Numbers
FG-02	KS-FG-02-30
FCG-02	KS-FCG-02-30
FG-03	KS-FG-03-30
FCG-03	KS-FCG-03-30

FG/FCG-06-250-* -30/3090
FG/FCG-10-500-* -30/3090

CAUTION

When making replacement of seals, please do it carefully after reading through the relevant instructions in the Operator's Manual.

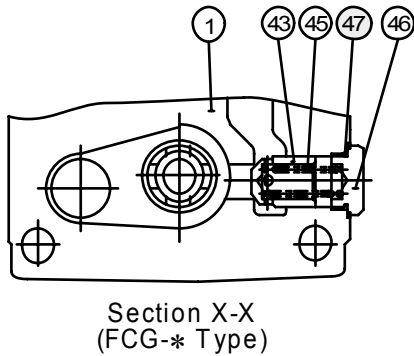
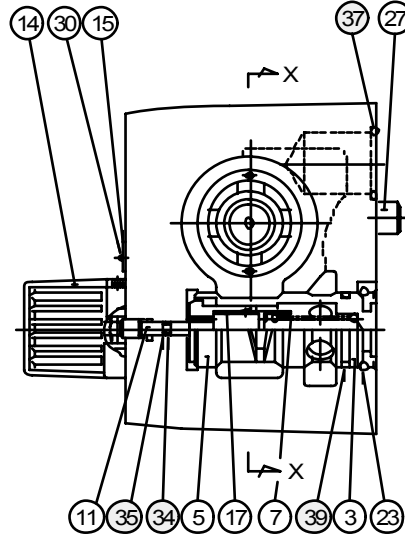
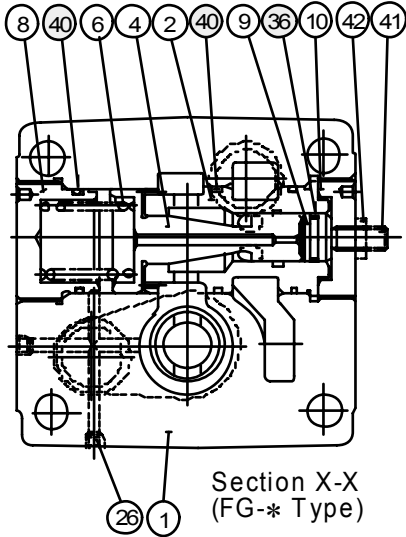

● List of Seals

Item	Name of Parts	Part Numbers		Qty.
		FG FCG-06	FG FCG-10	
34	O-Ring	SO-NA-P4	SO-NA-P4	1
35	Back Up Ring	SO-BB-P4	SO-BB-P4	1
36	O-Ring	SO-NB-P21	SO-NB-P34	1
37	O-Ring	SO-NB-P32	SO-NB-P48	2
39	O-Ring	SO-NB-P34	SO-NB-P50	1
40	O-Ring	SO-NB-P50	SO-NB-G75	3
47	O-Ring	SO-NB-P24	SO-NB-P32	1

Note) When ordering the seals, please specify the seal kit number from the table right.

● List of Seal Kits

Model Numbers	Seal Kit Numbers
FG-06	KS-FG-06-30
FCG-06	KS-FCG-06-30
FG-10	KS-FG-10-30
FCG-10	KS-FCG-10-30



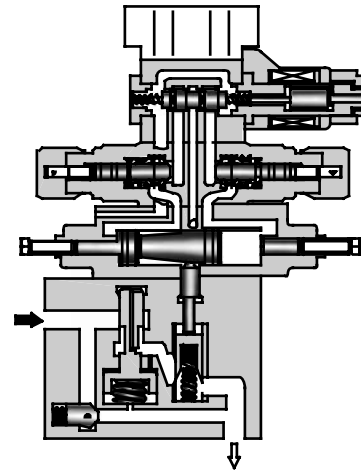

Specifications

Model Numbers	Max. Metred Flow Capacity L/min (U.S.GPM)	Min. Metred Flow Capacity L/min (U.S.GPM)	Max. Operating Pressure MPa (PSI)	Min. Pilot Pressure MPa (PSI)	Approx. Mass kg (lbs.)
FHG/FHCG-02-30-* -12*	30 (7.9)	0.05 (.013)	21 (3050)	1.5 (220)	13 (28.7)
FHG/FHCG-03-125-* -12*	125 (33)	0.2 (.053)			17 (37.5)
FHG/FHCG-06-250-* -12*	250 (66)	2 (.53)			32 (70.6)
FHG/FHCG-10-500-* -12*	500 (132)	4 (1.06)			61 (135)

Model Number Designation

F-	FHC	G	-02	-30	-N	-O	-A100	-N	-12	*
Special Seals	Series Number	Type of Mounting	Valve Size	Max. Metred Flow L/min (U.S.GPM)	Pressure Compensator Stroke Adj.	With No Pilot Valve [△]	Coil Type	Type of Electrical Connections	Design Number	Design Standards
F: Special Seals for Phosphate Ester Type Fluids (Omit if not required)	FH: Pilot Operated Flow Control Valves	G: Sub-plate Mounting	02	30 : 30 (7.9)	N: Applicable only for Pres. Compensator Stroke Adjustment (Option - Omit if not required)	O: Without Pilot Valve	AC: A100 A120 A200 A240 DC: D12 D24 D48 AC →DC: R100 R200	None: Terminal Box Type N: With Plug-in Connector (Din)	12	None: Japanese Std. "JIS" 90: N.American Design Std. 80: European Design Std.
			03	125 : 125 (33)					12	
	06		250 : 250 (66)	12						
	10		500 : 500 (132)	12						

★ Either solenoid operated directional valve (DSG-01) or modular valve (MSW-01) can be used as a pilot valve.
If no pilot valve is required, there is no needs to specify the coil type and the electrical connection type of solenoid operated directional valve.

Graphic Symbols

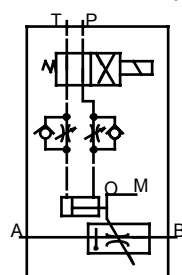

FHG

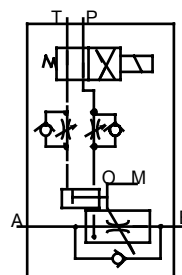

FHCG

■ Solenoid Ratings

Electric Source	Coil Type	Frequency (Hz)	Voltage (V)		Current & Power at Rated Voltage		
			Source Rating	Serviceable Range	Inrush (A)*	Holding (A)	Power (W)
AC	A100	50	100	80 - 110	2.42	0.51	—
		60	100	90 - 120	2.14	0.37	
			110		2.35	0.44	
	A120	50	120	96 - 132	2.02	0.42	
		60		108 - 144	1.78	0.31	
	A200	50	200	160 - 220	1.21	0.25	
		60		180 - 240	1.07	0.19	
				220	1.18	0.22	
A240	50	240	192 - 264	1.01	0.21		
	60		216 - 288	0.89	0.15		
DC (K Series)	D12	—	12	10.8 - 13.2	—	2.45	29
	D24		24	21.6 - 26.4		1.23	
	D48		48	43.2 - 52.8		0.61	
AC→DC Rectified	R100	50/60	100	90 - 110	—	0.33	29
	R200		200	180 - 220		0.16	

★ Inrush current in the above table shows rms values at maximum stroke.

The coil type numbers in the shaded column are handled as optional extras. In case these coils are required to be chosen, please confirm the time of delivery with us before ordering.

■ Attachment
● Mounting Bolts

Valve Model Numbers	Socket Head Cap Screw		Qty.
	Japanese Std. "JIS" & European Design Std.	N. American Design Std.	
FHG/FHCG-02	M8 × 50 Lg.	5/16-18 UNC × 2 Lg.	4
FHG/FHCG-03	M10 × 75 Lg.	3/8-16 UNC × 3 Lg.	4
FHG/FHCG-06	M16 × 130 Lg.	5/8-11 UNC × 5 Lg.	4
FHG/FHCG-10	M20 × 160 Lg.	3/4-10 UNC × 6-1/2 Lg.	4

■ Option
● Pres. compensator stroke adjustment

Can reduce jumping at the start of the actuator.

■ Sub-plate

Valve Model Numbers	Japanese Standard "JIS"		European Design Std.		N. American Design Std.		Approx. Mass kg (lbs.)
	Sub-plate Model No.	Thread Size	Sub-plate Model No.	Thread Size	Sub-plate Model No.	Thread Size	
FHG FHCG -02	FGM-02-20	Rc 1/4	FGM-02-2080	1/4 BSP.F	FGM-02-2090	1/4 NPT	2.3 (5.1)
	FGM-02X-20	Rc 3/8	FGM-02X-2080	3/8 BSP.F	FGM-02X-2090	3/8 NPT	2.3 (5.1)
	FGM-02Y-20	Rc 1/2	FGM-02Y-2080	1/2 BSP.F	FGM-02Y-2090	1/2 NPT	3.1 (6.8)
FHG FHCG -03	FGM-03-20	Rc 3/8	FGM-03-2080	3/8 BSP.F	FGM-03-2090	3/8 NPT	3.9 (8.6)
	FGM-03X-20	Rc 1/2	FGM-03X-2080	1/2 BSP.F	FGM-03X-2090	1/2 NPT	3.9 (8.6)
	FGM-03Y-20	Rc 3/4	FGM-03Y-2080	3/4 BSP.F	FGM-03Y-2090	3/4 NPT	5.7 (12.6)
	FGM-03Z-20	Rc 1	FGM-03Z-2080	1 BSP.F	FGM-03Z-2090	1 NPT	5.7 (12.6)
FHG FHCG -06	FGM-06X-20	Rc 1	FGM-06X-2080	1 BSP.F	FGM-06X-2090	1 NPT	12.5 (27.6)
	FGM-06Y-20	Rc 1-1/4	FGM-06Y-2080	1-1/4 BSP.F	FGM-06Y-2090	1-1/4 NPT	16 (35.3)
	FGM-06Z-20	Rc 1-1/2	FGM-06Z-2080	1-1/2 BSP.F	FGM-06Z-2090	1-1/2 NPT	16 (35.3)
FHG FHCG -10	FGM-10Y-20*	1-1/2, 2	FGM-10Y-20*	1-1/2, 2	FGM-10Y-2090*	1-1/2, 2	37 (81.6)

● Sub-plates are available. Specify the sub-plate model number from the table above. When sub-plates are not used, the mounting surface should have a good machined finish.

● Sub-plates are common with flow control valves. For dimensions, see pages 6 to 8.

★ FGM-10Y is special type sub-plates to be used with pipe flange. When ordering FGM-10Y, specify the pipe flange kit in addition to FGM-10Y referring to F3 pipe flange kits Catalogue (No. Pub. EC-3001).

■ Instructions

● Control patterns and flow rate adjustment

- While the solenoid operated directional valve on (② shown below), the flow rate is at the level set by the maximum flow adjustment screw and the actuator operates at the maximum speed setting. Turning the adjustment screw clockwise causes the flow rate to decrease.
- While the solenoid operated directional valve off (④ shown below), the flow rate is set by the minimum flow adjustment screw and the actuator operates at the minimum speed setting. Turning the adjustment screw clockwise causes the flow rate to increase.
- When the solenoid operated directional valve is turned on (① shown below), the flow rate is shifted from minimum to maximum and the actuator speed is also shifted likewise. The switching time can be set by the pilot flow adjustment dial (for acceleration). Turning the adjustment dial clockwise causes the pilot flow rate to decrease.
- When the solenoid operated directional valve is turned off (③ shown below), the flow rate is shifted from maximum to minimum and the actuator speed is also shifted likewise. The switching time can be set by the pilot flow adjustment dial (for deceleration). Turning the adjustment dial clockwise causes the pilot flow rate to decrease.

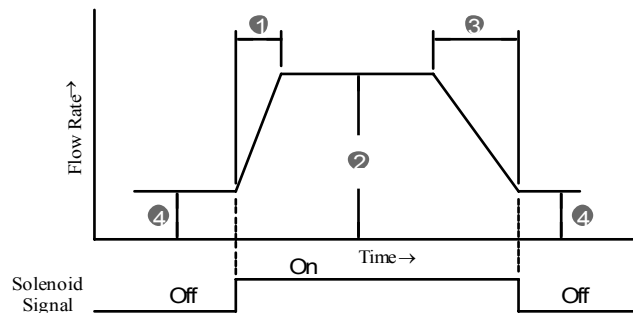

● Tightening of flow adjustment screws and dials

To adjust flow rates, slacken the lock nut or the dial setting screw. After adjustments, tighten the lock nut or the dial.

● Min. required pressure difference

The minimum differential pressure between inlet and outlet port is required to obtain the optimum pressure compensation. It varies according to the flow rate to be set. For details, please refer to the performance curves.

● Free flow

Check valve pressure drops vary with flow rates. If models with check valves are used, see free flow pressure drop characteristics.

● Line filter

To carry out flow adjustments by as small degree as 2 L/min (.53 U.S.GPM) or less, be sure to use a line filter of 10 μ m or finer and install it near the valve inlet.

Metred Flow vs. Cylinders Stroke

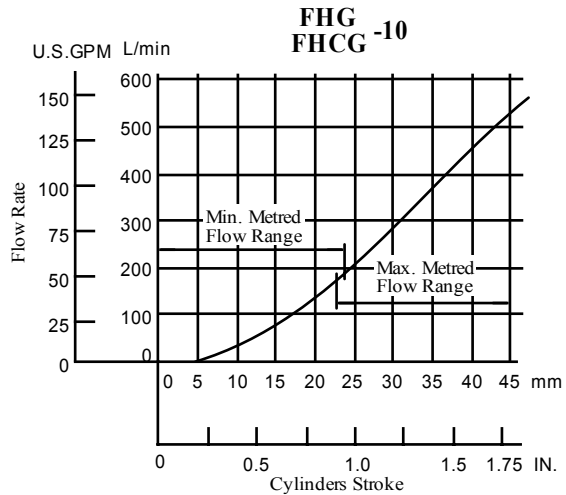
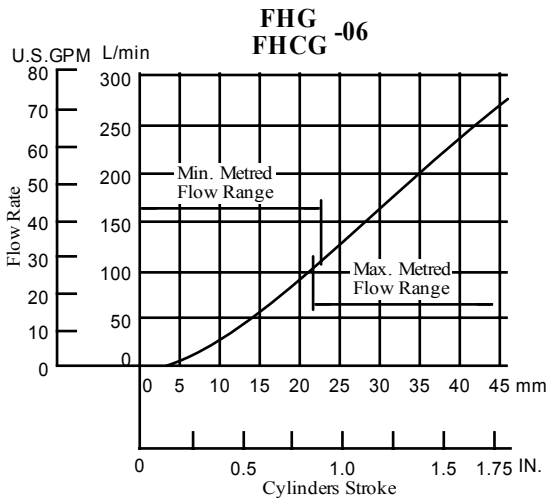
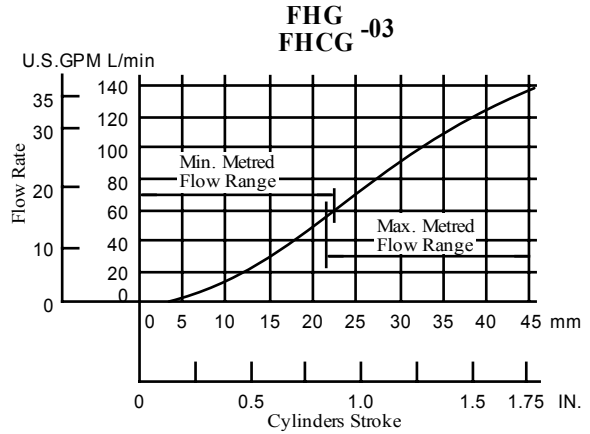
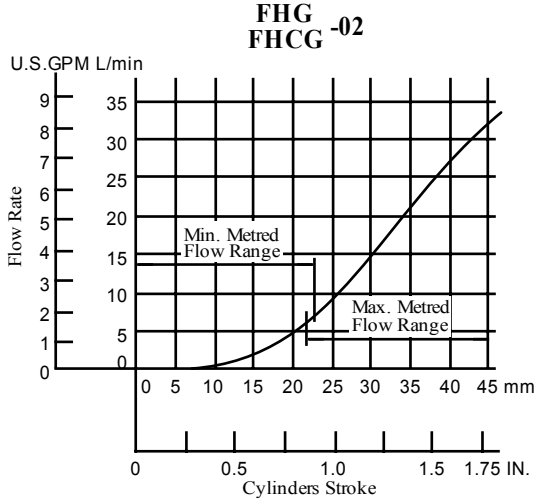

Other Characteristics

The following characteristics are the same as for flow control valves;

- Metred Flow vs. Differential Pressure
- Metred Flow vs. Viscosity
- Min. Required Pressure Difference
- Pressure Drop for Reversed Free Flow (only for models with check valves)

See pages 9 to 11. For reference, the corresponding model No. of the flow control valves are shown below.

Valve Model No.	Model No.
FHG FHCG -02	FG FCG -02
FHG FHCG -03	FG FCG -03
FHG FHCG -06	FG FCG -06
FHG FHCG -10	FG FCG -10

● Terminal Box Type

FHG/FHCG-02-30-*-*-12/1290
FHG/FHCG-03-125-*-*-12/1290

Mounting surface:
FH*G-02: ISO 6263-AK-06-2-A
FH*G-03: ISO 6263-AM-07-2-A

**DIMENSIONS IN
MILLIMETRES (INCHES)**

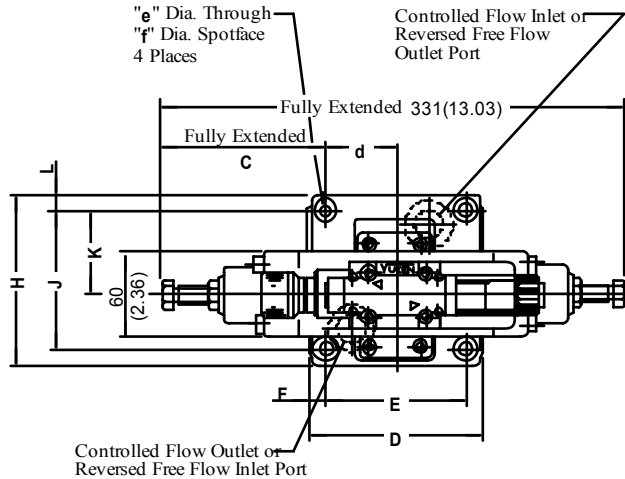

Model Numbers	n	t
FHG/FHCG-02-30-*-*-12	Rc 1/4	G 1/2
FHG/FHCG-02-30-*-*-1290	1/4 NPT	1/2 NPT
FHG/FHCG-03-125-*-*-12	Rc 1/4	G 1/2
FHG/FHCG-03-125-*-*-1290	1/4 NPT	1/2 NPT

Note: For dimensions of the valve mounting surface, see the installation drawing (P. 6 and 7) of the sub-plate used together.

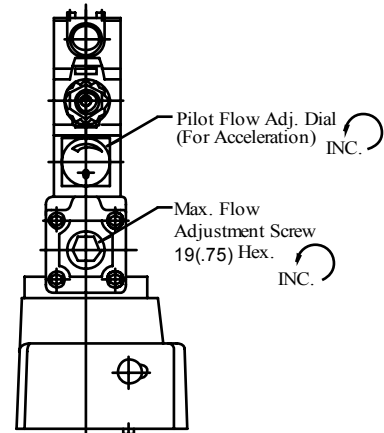
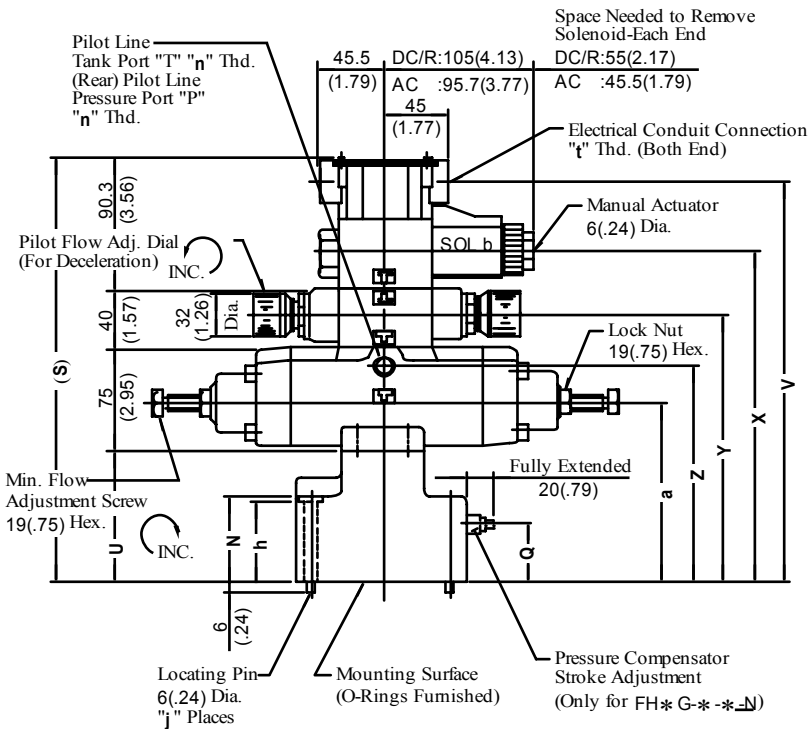

Model Numbers	Dimensions mm (Inches)															
	C	D	E	F	H	J	K	L	N	Q	S	U	V	X	Y	Z
FHG FHCG -02	127.4 (5.02)	96 (3.78)	76.2 (3.00)	9.9 (.39)	100.6 (3.96)	82.6 (3.25)	44.3 (1.74)	9 (.35)	40 (1.57)	23 (.91)	274.3 (10.80)	69 (2.72)	256 (10.08)	209 (8.23)	162 (6.38)	129 (5.08)
FHG FHCG -03	114.7 (4.52)	125 (4.92)	101.6 (4.00)	11.7 (.46)	125 (4.92)	101.6 (4.00)	61.8 (2.43)	11.7 (.46)	64 (2.52)	41 (1.61)	303.3 (11.94)	98 (3.86)	285 (11.22)	238 (9.37)	191 (7.52)	158 (6.22)

Model Numbers	Dimensions mm (Inches)					j
	a	d	e	f	h	
FHG FHCG -02	104 (4.09)	38.1 (1.50)	8.8 (.35)	14 (.55)	39 (1.54)	1
FHG FHCG -03	133 (5.24)	50.8 (2.00)	11 (.43)	17.5 (.69)	63 (2.48)	2

● Models with Plug-in Connector

FHG/FHCG-02-30-*-*-N-12/1280/1290

FHG/FHCG-03-125-*-*-N-12/1280/1290

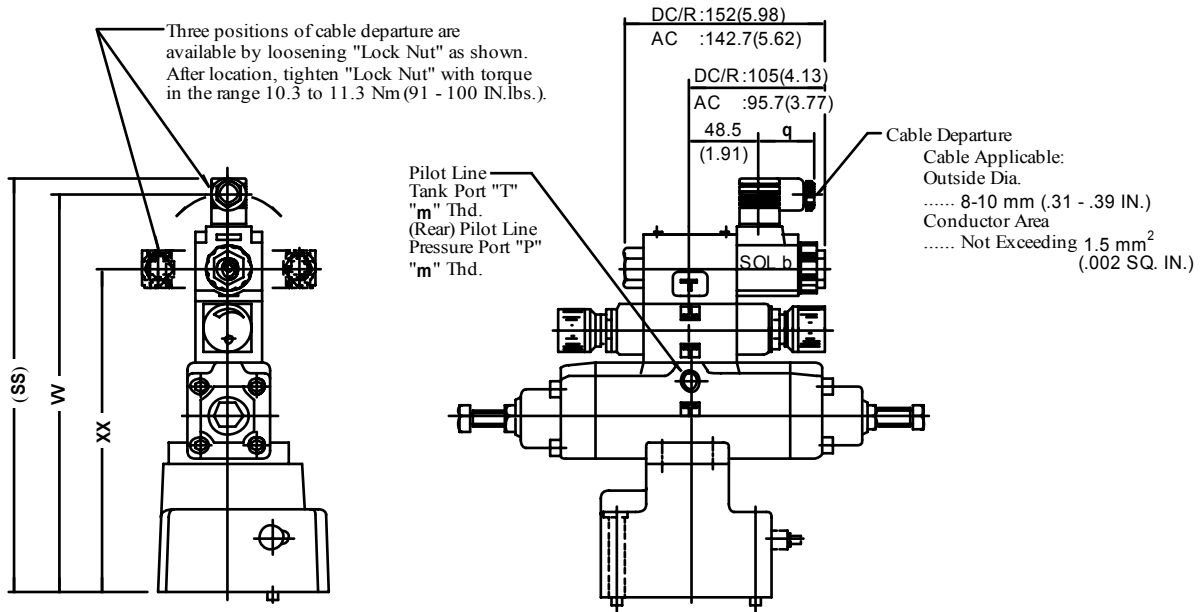

DIMENSIONS IN
MILLIMETRES (INCHES)

Model Numbers	Dimensions mm (Inches)				Remarks
	SS	W	XX	q	
FHG/FHCG-02-30-*-*-A*-N	274 (10.79)	262 (10.31)	209 (8.23)	39 (1.54)	with AC Solenoid
FHG/FHCG-03-125-*-*-A*-N	303 (11.93)	291 (11.46)	238 (9.37)		
FHG/FHCG-02-30-*-*-D*-N	285 (11.22)	273 (10.75)	209 (8.23)	39 (1.54)	with DC Solenoid
FHG/FHCG-03-125-*-*-D*-N	314 (12.36)	302 (11.89)	238 (9.37)		
FHG/FHCG-02-30-*-*-R*-N	288 (11.34)	266.2 (10.48)	209 (8.23)	53 (2.09)	with AC→DC Solenoid
FHG/FHCG-03-125-*-*-R*-N	317 (12.48)	295.2 (11.62)	238 (9.37)		

Model Numbers	Thread Size		
	Japanese Std. "JIS" Design 12	European Design Std. Design 1280	N.American Design Std. Design 1290
	"n" Thd.	"n" Thd.	"n" Thd.
FHG/FHCG-02-30-*-*-N	Rc 1/4	1/4 BSP.F	1/4 NPT
FHG/FHCG-03-125-*-*-N			

● For other dimensions, refer to "Terminal Box Type".



● Terminal Box Type

FHG/FHCG-06-250-*-*-12/1290
FHG/FHCG-10-500-*-*-12/1290

Mounting surface:
FH*G-06: ISO 6263-AP-08-2-A

DIMENSIONS IN
MILLIMETRES (INCHES)

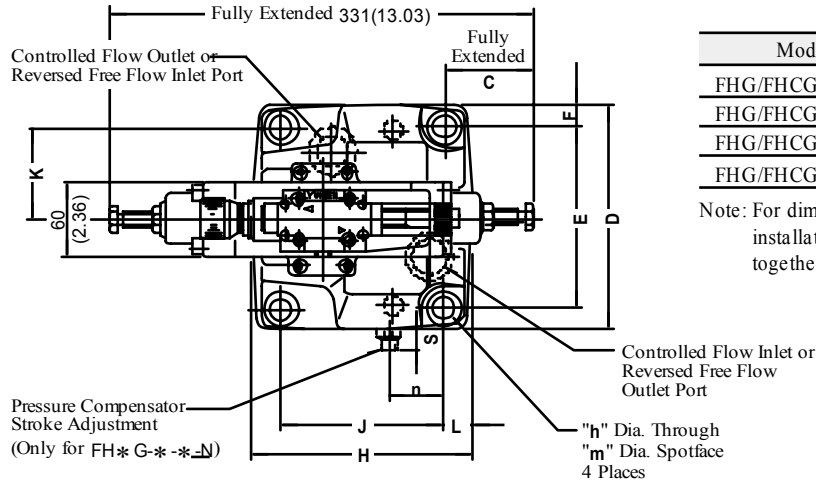

Model Numbers	q	r
FHG/FHCG-06-250-*-*-12	Rc 1/4	G 1/2
FHG/FHCG-06-250-*-*-1290	1/4 NPT	1/2 NPT
FHG/FHCG-10-500-*-*-12	Rc 1/4	G 1/2
FHG/FHCG-10-500-*-*-1290	1/4 NPT	1/2 NPT

Note: For dimensions of the valve mounting surface, see the installation drawing (P. 7 and 8) of the sub-plate used together.

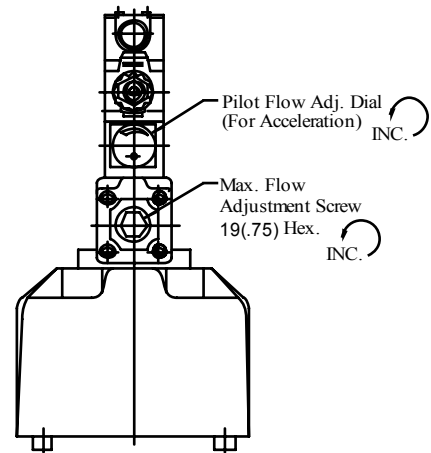
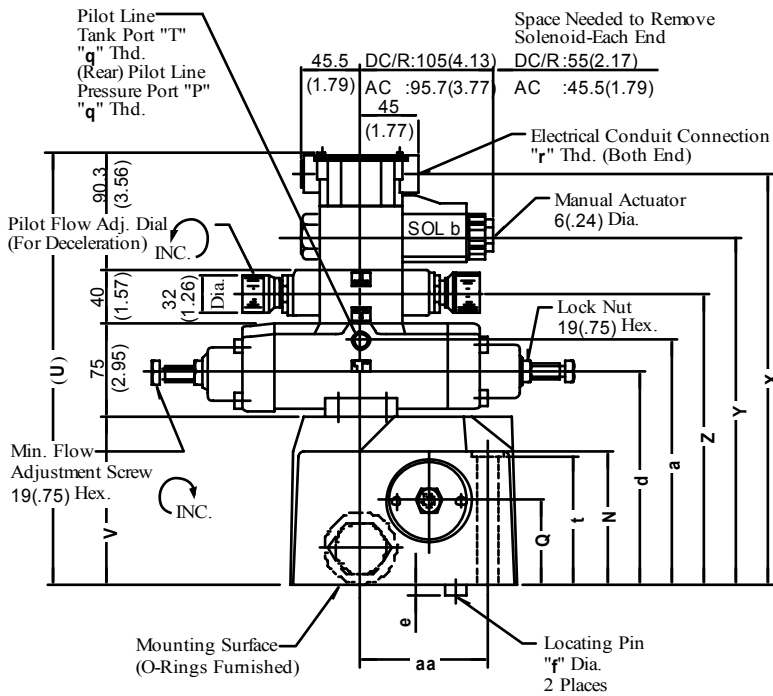

Model Numbers	Dimensions mm (Inches)															
	C	D	E	F	H	J	K	L	N	Q	S	U	V	X	Y	Z
FHG FHCG -06	66.5 (2.62)	180 (7.09)	146.1 (5.75)	17 (.67)	174 (6.85)	133.4 (5.25)	73.1 (2.88)	20.3 (.80)	105 (4.13)	65 (2.56)	18 (.71)	335.3 (13.20)	130 (5.12)	317 (12.48)	270 (10.63)	223 (8.78)
FHG FHCG -10	21 (.83)	244 (9.61)	196.9 (7.75)	23.5 (.93)	228 (8.98)	177.8 (7.00)	98.5 (3.88)	25.1 (.99)	137 (5.39)	85 (3.35)	23 (.91)	365.3 (14.38)	160 (6.30)	347 (13.66)	300 (11.81)	253 (9.96)

Model Numbers	Dimensions mm (Inches)								
	a	d	e	f	h	m	n	t	aa
FHG FHCG -06	190 (7.48)	165 (6.50)	7 (.28)	16 (.63)	17.5 (.69)	26 (1.02)	44 (1.73)	103 (4.06)	99 (3.90)
FHG FHCG -10	220 (8.66)	195 (7.68)	10 (.39)	18 (.71)	21.5 (.85)	32 (1.26)	61 (2.40)	135 (5.31)	144.5 (5.69)

● Models with Plug-in Connector

FHG/FHCG-06-250-*-*-N-12/1280/1290

FHG/FHCG-10-500-*-*-N-12/1280/1290

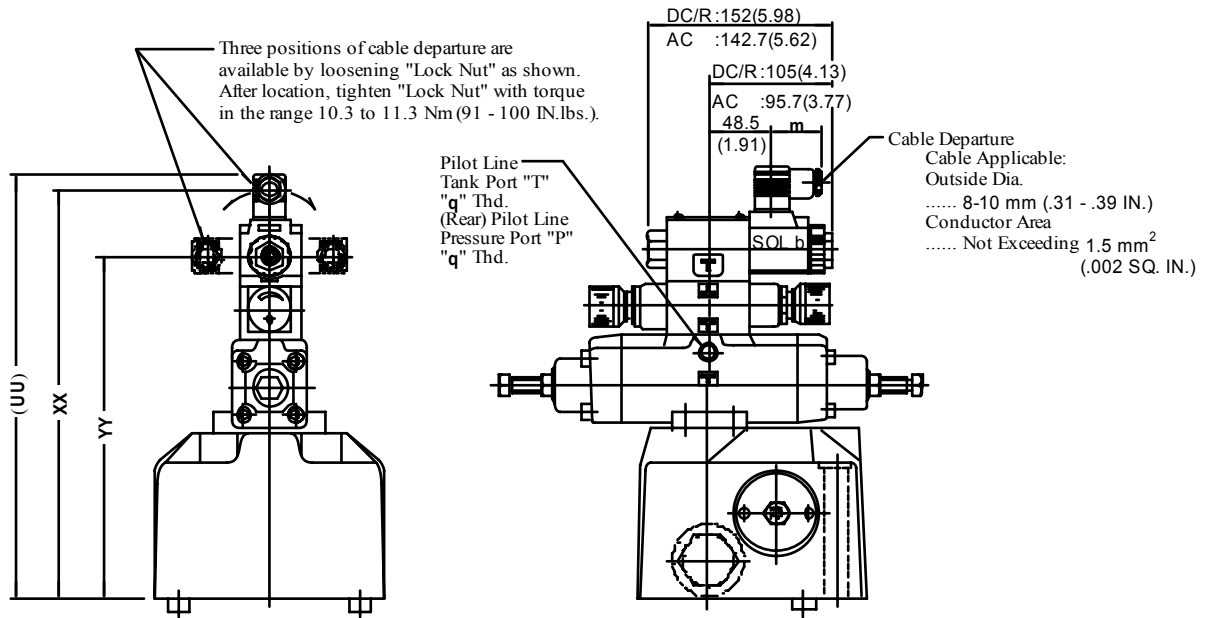

DIMENSIONS IN
MILLIMETRES (INCHES)

Model Numbers	Dimensions mm (Inches)				Remarks
	UU	XX	YY	m	
FHG/FHCG-06-250-*-*-A*-N	335 (13.19)	323 (12.72)	270 (10.63)	39 (1.54)	with AC Solenoid
FHG/FHCG-10-500-*-*-A*-N	365 (14.37)	353 (13.90)	300 (11.81)		
FHG/FHCG-06-250-*-*-D*-N	346 (13.62)	334 (13.15)	270 (10.63)	39 (1.54)	with DC Solenoid
FHG/FHCG-10-500-*-*-D*-N	376 (14.80)	364 (14.33)	300 (11.81)		
FHG/FHCG-06-250-*-*-R*-N	349 (13.74)	327.2 (12.88)	270 (10.63)	53 (2.09)	with AC→DC Solenoid
FHG/FHCG-10-500-*-*-R*-N	379 (14.92)	357.2 (14.06)	300 (11.81)		

Model Numbers	Thread Size		
	Japanese Std. "JIS" Design 12	European Design Std. Design 1280	N.American Design Std. Design 1290
	"q" Thd.	"q" Thd.	"q" Thd.
FHG/FHCG-06-250-*-*-N	Rc 1/4	1/4 BSP.F	1/4 NPT
FHG/FHCG-10-500-*-*-N			

● For other dimensions, refer to "Terminal Box Type".



Lead Wire Connection

Details of Receptacle

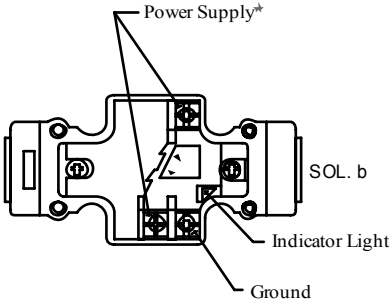
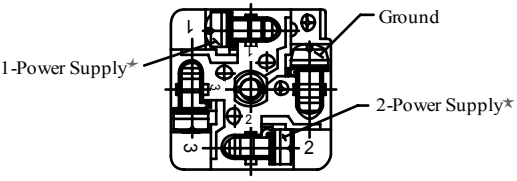
Terminal Box Type	Plug-in Connector Type
 <p>Power Supply*</p> <p>SOL. b</p> <p>Indicator Light</p> <p>Ground</p>	 <p>1-Power Supply*</p> <p>Ground</p> <p>2-Power Supply*</p>

★ With DC solenoids, polarity is no question.

DANGER

- Do not perform wiring while the power is on. Doing so may result in electric shock, burns or death.
- Make the wiring properly. Improper wiring will cause an irregular movement of the machine, resulting in a grave accident.

Electrical Circuit

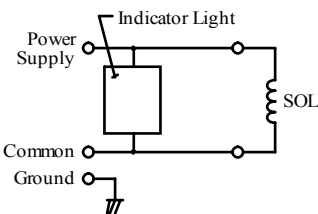
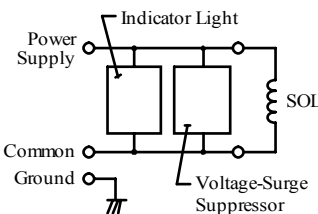
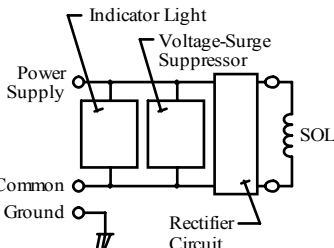
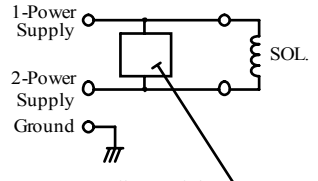
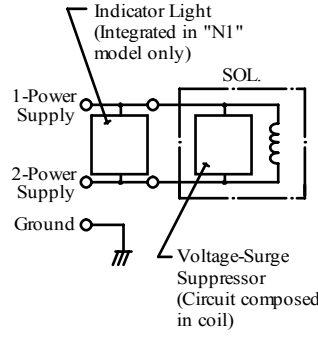
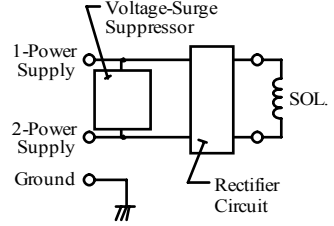
Type of Electrical Conduit Connection	Electric Source		
	AC	DC	AC →DC Rectified
Terminal Box Type	 <p>Indicator Light</p> <p>Power Supply</p> <p>Common</p> <p>Ground</p> <p>SOL.</p>	 <p>Indicator Light</p> <p>Power Supply</p> <p>Common</p> <p>Ground</p> <p>SOL.</p> <p>Voltage-Surge Suppressor</p>	 <p>Indicator Light</p> <p>Power Supply</p> <p>Common</p> <p>Ground</p> <p>SOL.</p> <p>Voltage-Surge Suppressor</p> <p>Rectifier Circuit</p>
Plug-in Connector Type	 <p>1-Power Supply</p> <p>2-Power Supply</p> <p>Ground</p> <p>SOL.</p> <p>Indicator Light (Integrated in "N1" model only)</p>	 <p>Indicator Light (Integrated in "N1" model only)</p> <p>1-Power Supply</p> <p>2-Power Supply</p> <p>Ground</p> <p>SOL.</p> <p>Voltage-Surge Suppressor (Circuit composed in coil)</p>	 <p>Voltage-Surge Suppressor</p> <p>1-Power Supply</p> <p>2-Power Supply</p> <p>Ground</p> <p>SOL.</p> <p>Rectifier Circuit</p>

CAUTION

When making replacement of seals, please do it carefully after reading through the relevant instructions in the Operator's Manual.

● Terminal Box Type

FHG/FHCG-02-30-*-*/-12/1290
FHG/FHCG-03-125-*-*/-12/1290

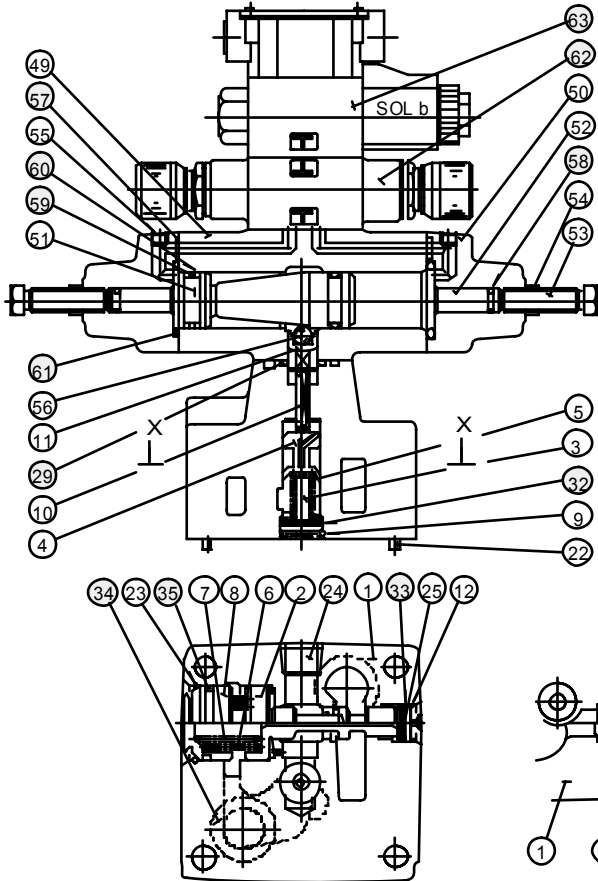

(FHG-* Type)

● Models with Plug-in Connector

FHG/FHCG-02-30-*-*/-N-12/1280/1290
FHG/FHCG-03-125-*-*/-N-12/1280/1290

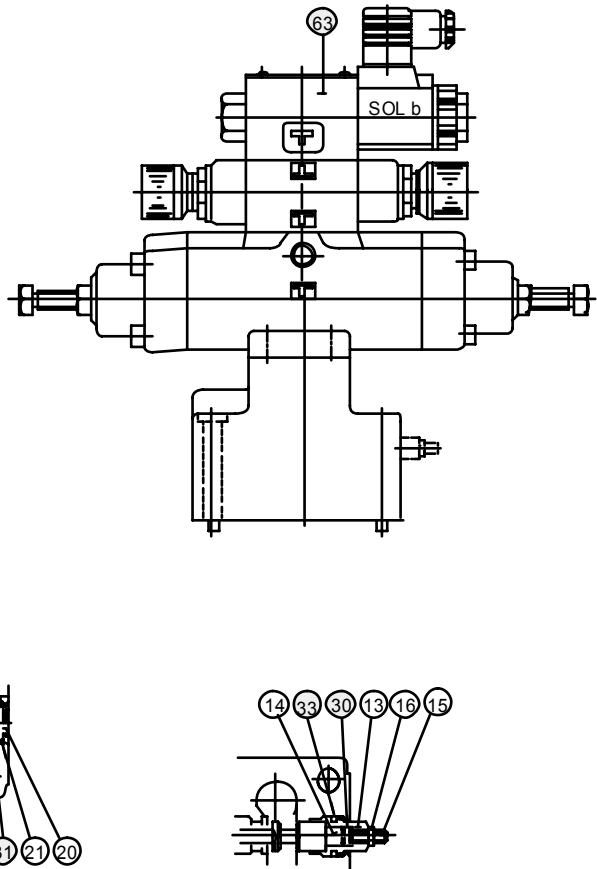

(FHCG-* Type)
Section X-X

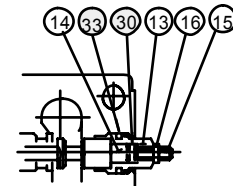

(FHG/FHCG-*-*/-N Type)

● List of Seals

Item	Name of Parts	Part Numbers		Qty.
		FHG FHCG -02	FHG FHCG -03	
29	O-Ring	SO-NB-P20	SO-NB-P20	1
30	O-Ring	SO-NB-P5	SO-NB-P5	1
31	O-Ring	SO-NB-P10A	SO-NB-P16	1
32	O-Ring	SO-NB-P12	SO-NB-P18	1
33	O-Ring	SO-NB-P14	SO-NB-P14	1
34	O-Ring	SO-NB-P18	SO-NB-P28	2
35	O-Ring	SO-NB-G25	SO-NB-G35	1
57	O-Ring	SO-NB-P9	SO-NB-P9	2
58	O-Ring	SO-NB-P10A	SO-NB-P10A	2
59	O-Ring	SO-NA-P26	SO-NA-P26	2
60	Back Up Ring	SO-BB-P26	SO-BB-P26	4
61	O-Ring	SO-NB-P38	SO-NB-P38	2

Note) When ordering the seals, please specify the sealkit number from the table right. In addition to the above seals, seals for pilot valves are included in the seal kit.

● Pilot Valves

See page 25 for the pilot valve model numbers to be used.

● List of Seal Kits

Model Numbers	Seal Kit Numbers
FHG-02	KS-FHG-02-12
FHCG-02	KS-FHCG-02-12
FHG-03	KS-FHG-03-12
FHCG-03	KS-FHCG-03-12



CAUTION

When making replacement of seals, please do it carefully after reading through the relevant instructions in the Operator's Manual.

● Terminal Box Type

FHG/FHCG-06-250-*-*/12/1290

FHG/FHCG-10-500-*-*/12/1290

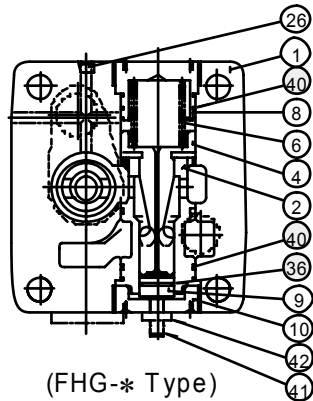
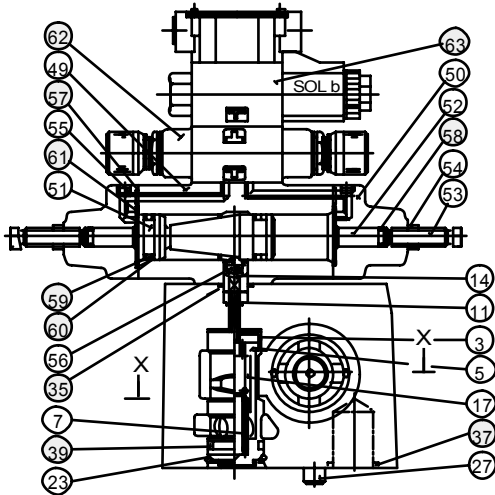

(FHG-* Type)
Section X-X

● Models with Plug-in Connector

FHG/FHCG-06-250-*-*/N-12/1280/1290

FHG/FHCG-10-500-*-*/N-12/1280/1290

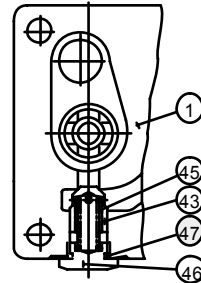
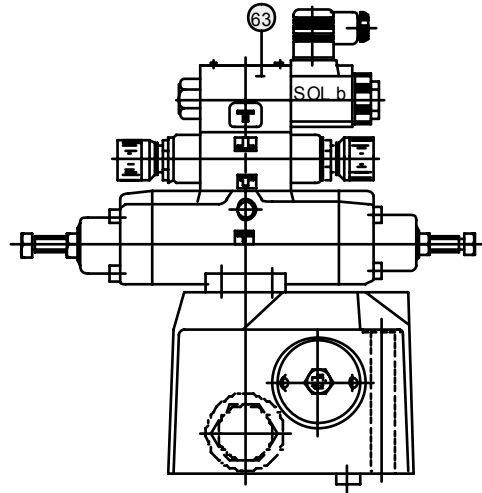

(FHCG-* Type)
Section X-X

● List of Seals

Item	Name of Parts	Part Numbers		Qty.
		FHG FHCG-06	FHG FHCG-10	
35	O-Ring	SO-NB-P20	SO-NB-P20	1
36	O-Ring	SO-NB-P21	SO-NB-P34	1
37	O-Ring	SO-NB-P32	SO-NB-P48	2
39	O-Ring	SO-NB-P34	SO-NB-P50	1
40	O-Ring	SO-NB-P50	SO-NB-G75	3
47	O-Ring	SO-NB-P24	SO-NB-P32	1
57	O-Ring	SO-NB-P9	SO-NB-P9	2
58	O-Ring	SO-NB-P10A	SO-NB-P10A	2
59	O-Ring	SO-NA-P26	SO-NA-P26	2
60	Back Up Ring	SO-BB-P26	SO-BB-P26	4
61	O-Ring	SO-NB-P38	SO-NB-P38	2

Note) When ordering the seals, please specify the seal kit number from the table right. In addition to the above seals, seals for pilot valves are included in the seal kit.

● Pilot Valves

See page 25 for the pilot valve model numbers to be used.

● List of Seal Kits

Model Numbers	Seal Kit Numbers
FHG-06	KS-FHG-06-12
FHCG-06	KS-FHCG-06-12
FHG-10	KS-FHG-10-12
FHCG-10	KS-FHCG-10-12

● List of Pilot Valves

Type of Electrical Conduit Connections	Valve Model Numbers	Pilot Valve Model Numbers		Remarks
		Item No.62 Throttle and Check Modular Valves	Item No.63 Solenoid Operated Directional Valves	
Terminal Box Type	FHG/FHCG-02- 30-*-* -12 FHG/FHCG-03- 125-*-* -12 FHG/FHCG-06- 250-*-* -12 FHG/FHCG-10- 500-*-* -12	MSW-01-X-50	DSG-01-2B2-* -60	Japanese Std. "JIS"
	FHG/FHCG-02- 30-*-* -1290 FHG/FHCG-03- 125-*-* -1290 FHG/FHCG-06- 250-*-* -1290 FHG/FHCG-10- 500-*-* -1290	MSW-01-X-5090	DSG-01-2B2-* -6090	N. American Design Std.
Plug-in Connector Type	FHG/FHCG-02- 30-*-* -N-12 FHG/FHCG-03- 125-*-* -N-12 FHG/FHCG-06- 250-*-* -N-12 FHG/FHCG-10- 500-*-* -N-12	MSW-01-X-50	DSG-01-2B2-* -N-60	Japanese Std. "JIS"
	FHG/FHCG-02- 30-*-* -N-1280 FHG/FHCG-03- 125-*-* -N-1280 FHG/FHCG-06- 250-*-* -N-1280 FHG/FHCG-10- 500-*-* -N-1280	MSW-01-X-50	DSG-01-2B2-* -N-60	European Design Std.
	FHG/FHCG-02- 30-*-* -N-1290 FHG/FHCG-03- 125-*-* -N-1290 FHG/FHCG-06- 250-*-* -N-1290 FHG/FHCG-10- 500-*-* -N-1290	MSW-01-X-5090	DSG-01-2B2-* -N-6090	N. American Design Std.

Note: 1. Fill a coil type (a symbol representing current/voltage) in section marked * .
 2. For the detail of the MSW-01 valve O-rings, see the Catalogue No. Pub. EC-1402.
 3. For the detail of the DSG-01 valve O-rings, see the Catalogue No. Pub. EC-0402.

